

Stenhøj Maestro 2.32

Stenhøj Maestro 2.32

2-post electro-mechanical lifts

The STENHØJ Maestro 2.32 lifts are electro-mechanical asymmetric lifts with lifting capacities of 3.2 t.

Maestro 2.32 is available with either flex pads, combiflex pads or our new combiflex-08 pads.

The lifts are delivered as standard with programmable top stop, which enables you to program the lift to stop in the same working position every time the lift is raised. This ensures an ergonomically correct working position for the mechanics.

We offer a large program of both U and flex pads for all models.



Flex pad:
Min. height: 85 mm.
Max. height: 115 mm

Combiflex pad:
Min. height: 95 mm
Max. height: 255 mm

Combiflex-08-pad:
Min. height: 95 mm
Max. height: 250 mm



STENHØJ
lifting the level

Stenhøj Maestro 2.32

Stenhøj Maestro 2.32

2-post electro-mechanical lifts

We can now offer three auxiliary packages:

Package 1:
Air and power unit
Extra control unit
Rechargeable LED lamp

Package 2:
Air and power unit
Extra control unit

Package 3:
Air and power unit
Rechargeable LED lamp



Nut breakage system.

The most durable nut set on the market.



Internal arm locking device that automatically releases in bottom position.



Control unit with dead-man controls and separate main switch.



STENHØJ
lifting the level

Stenhøj Maestro 2.32

Stenhøj Maestro 2.32

2-post electro-mechanical lifts

Maestro 2.32 is now equipped with newly designed door stops; and can be delivered with collapsible wheel holders (optional extras).



Arms can be parallel-parked.



6 large guiding wheels.



Cold-rolled, centered spindle for very long life.



STENHØJ
lifting the level

CORROSION-PROOF SURFACE TREATMENT

Stenhøj lifts are led through a sling purifying plant (according to SA2.50 – ISO-Norm 8501-1:2007), dipped in primer, and finally led through an electro-static powder bake plant.

Technical data

Lifting capacity 3200 kg
 Lifting/lowering time 40 sec.
 Motor 2 x 1.5 kW

	A	B	C	D	E	F	G	H	I	J	K	L
F	3240-3440	2380-2580	2960-3160	3120-3320	4050/4350	2713	1900	2020	2120-2320	550	465	Ø120
CF	3240-3440	2380-2580	2960-3160	3120-3320	4050/4350	2713	1900	2155	2120-2320	550	465	Ø120
CF-08	3240-3440	2380-2580	2960-3160	3120-3320	4050/4350	2713	1900	2030	2120-2320	550	465	Ø120
	M	N	O	P	Q	R	S	T	U	V	W	X
F	540	850	900	1425	95	115	85			100	190	260
CF	580	890	935	1425	95	255	95	225	25	100	190	
CF-08	555	840	920	1415	92	250	95			100	190	

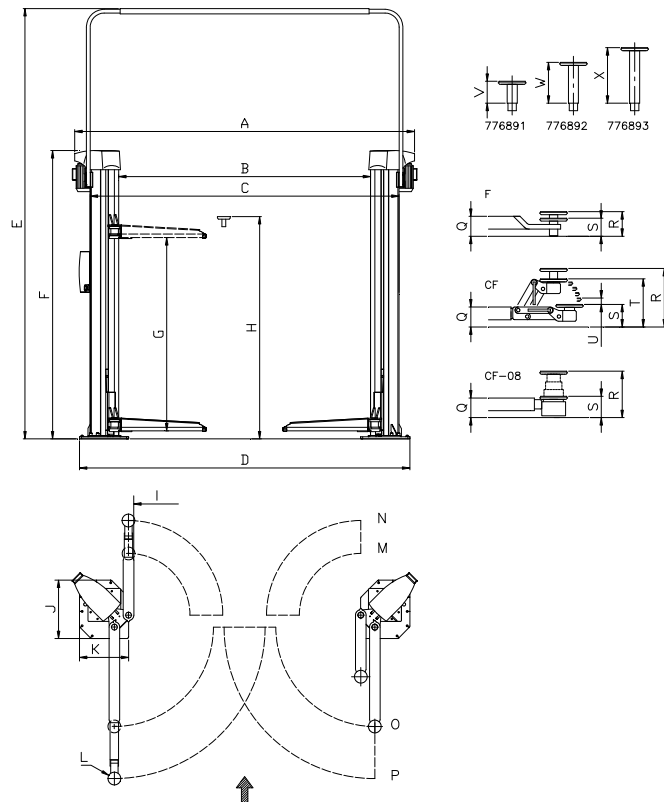

STENHØJ
 lifting the level

Stenhøj Autolift A/S
 Denmark

Tel: +45 76 82 13 30
 Fax: +45 76 82 13 31
 Mail: autolift@stenhoj.dk
 Web: www.stenhoj.dk

Standard colours

Red RAL 3013
 White RAL 9002

No liability accepted for specifications, which are subject to alteration.