

Stenhøj Maestro 2.50

Stenhøj Maestro 2.50

2-post electro-mechanical lifts

STENHØJ Maestro 2.50 is suitable for all kinds of repair jobs.

Double telescopic arms lift all small, medium-sized and large types of passenger cars and vans.

Maestro 2.50 has a lifting capacity of 5 t and is equipped with a programmable top stop.

Slim, symmetric construction gives easy access and allows lifting of very long vehicles.



Delivered as standard with 30-60 mm flex pads.



Nut breakage system.



We offer as optional extras a large program of U- and flex pads; fixed as well as adjustable. We also offer pads especially developed for VW Crafter and Sprinter.



STENHØJ
lifting the level

CORROSION-PROOF SURFACE TREATMENT

Stenhøj lifts are led through a sling purifying plant (according to SA2.50 – ISO-Norm 8501-1:2007), dipped in primer, and finally led through an electro-static powder bake plant.

<u>Technical data</u>	2.50 FL	2.50 F, 127 mm
Lifting capacity	5000 kg	5000 kg.
Lifting/lowering time	55 sec.	55 sec.
Lifting height	2070 mm	2052 mm
Min. height	140 mm	122 mm
Motor	2 x 2.8 kW	2 x 2.8 kW
Min./max. arm length	957 mm/2138 mm	875 mm/1960 mm

Model	A	B	C	D	E	F	G	H	I	J
2.50 FL	4095-4295	3185-3385	3560-3760	3910-4110	2908	3495-5270	1900	2070	150	140
2.50 F, 122 mm.	4095-4295	3185-3385	3560-3760	3910-4110	2908	3495-5270	1900	2052	150	122

	K	L	M	N	O	P	Q	R	S	T
2.50 FL	170	2800-3000	957	2138	957	2138	520	610	2075	4436
2.50 F, 122 mm.	152	2800-3000	875	1960	875	1960	520	610	1910	4080

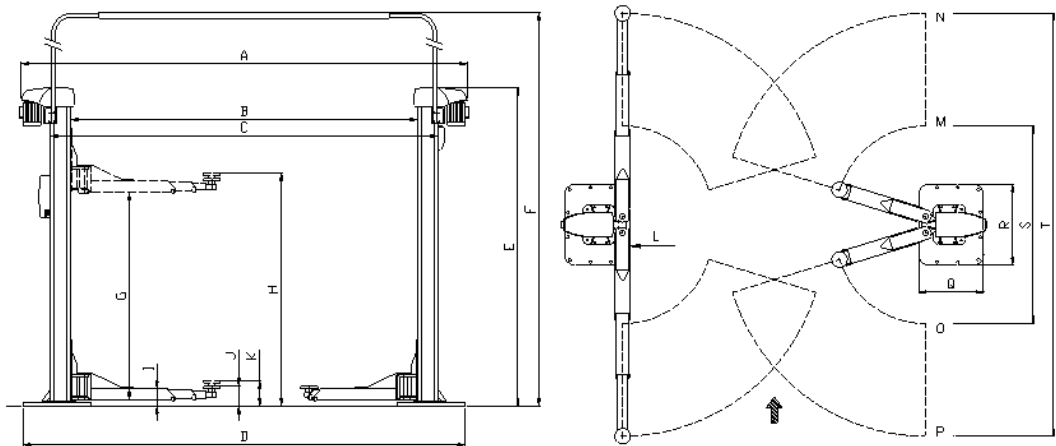

STENHØJ
lifting the level

Stenhøj Autolift A/S
Denmark

Tel: +45 76 82 13 30
Fax: +45 76 82 13 31
Mail: autolift@stenhoj.dk
Web: www.stenhoj.dk

Standard colours

Red RAL 3013
White RAL 9002

No liability accepted for specifications, which are subject to alteration.