

Stenhøj Biglift 4.60 Saaa

Stenhøj Biglift 4.60 Saaa

Twin-ram lifts with arms

The STENHØJ Biglift are twin-ram hydraulic lifts with triple telescopic arms and adjustable flex pads.

The lift is developed for quick and easy lifting of all sizes vans.

The lift is suitable for all kinds of repairs that require free access to wheels and underbody; e.g. removal and repair of motor, transmission etc.

Due to the triple telescopic arms and a very low min. height Biglift can be used for lifting of small cars up to big transporters.

Biglift is available in 2 widths and has a lifting capacity of 6 t.



2 x 2 hard-chrome plated and inversed hydraulic cylinders running on teflon rings.

We offer a large program of extra pads; fixed as well as adjustable.

Biglift 4.60 Saaa 230 wide version – 2285 mm between pistons.

Stenhøj Biglift 4.60 Saaa

SURFACE TREATMENT

Corrosion inhibited steel cassette, which on request can be delivered as self-carrying and galvanized or plastic coated. Superstructure has been primed and then given two-component paint.

<u>Technical data</u>	4.60 Saaa 145	4.60 Saaa 230
Lifting capacity	6000 kg	6000 kg
Lifting/lowering time	45 sec.	45 sec.
Stroke length	1850 mm	1850 mm
Distance between pistons	1485 mm	2285 mm
Piston diameter	4 x 123 mm	4 x 123 mm
Foundation depth	2665 mm	2665 mm
Hydraulic pump	3 kW	3 kW
Oil volume	8 l	8 l

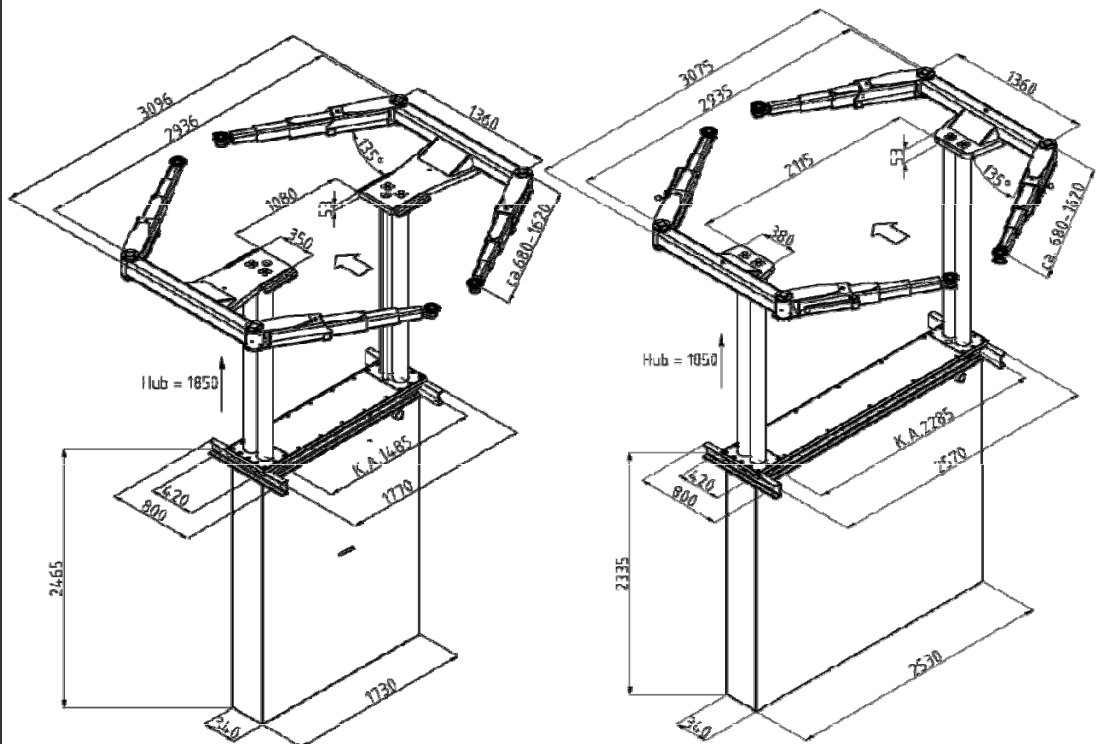

STENHØJ
lifting the level

Stenhøj Autolift A/S
Denmark

Tel: +45 76 82 13 30
Fax: +45 76 82 13 31
Mail: autolift@stenhoj.dk
Web: www.stenhoj.dk

Standard colours

Red RAL 3013

No liability accepted for specifications, which are subject to alteration.