

Stenhøj Master Body

Stenhøj Master Body

Twin-ram underground lifts

STENHØJ Master Body are hydraulic lifts with arms.

The lifts are especially suitable for body work, and because of the wide distance between pistons also for work with alignment benches.

The Master Body lifts have lifting capacities of 3 and 4 t.

We offer a large program of extra flex and U-pads for these lift types.



Identification of a Master Body lift:

First digit (2) = number of pistons

Next 2 digits (e.g. 30) = capacity in 100 kg

Letters:

Sav = telescopic, adjustable in length, movable superstructure

Saav = double telescopic, adjustable in length, movable superstructure



STENHØJ
lifting the level

Stenhøj Master Body

Stenhøj Master Body 2.30 Sav 230

Twin-ram underground lifts

All twin-ram lifts are available pre-fitted from factory.

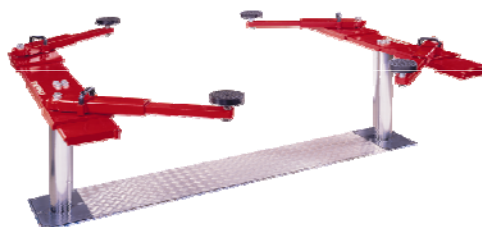
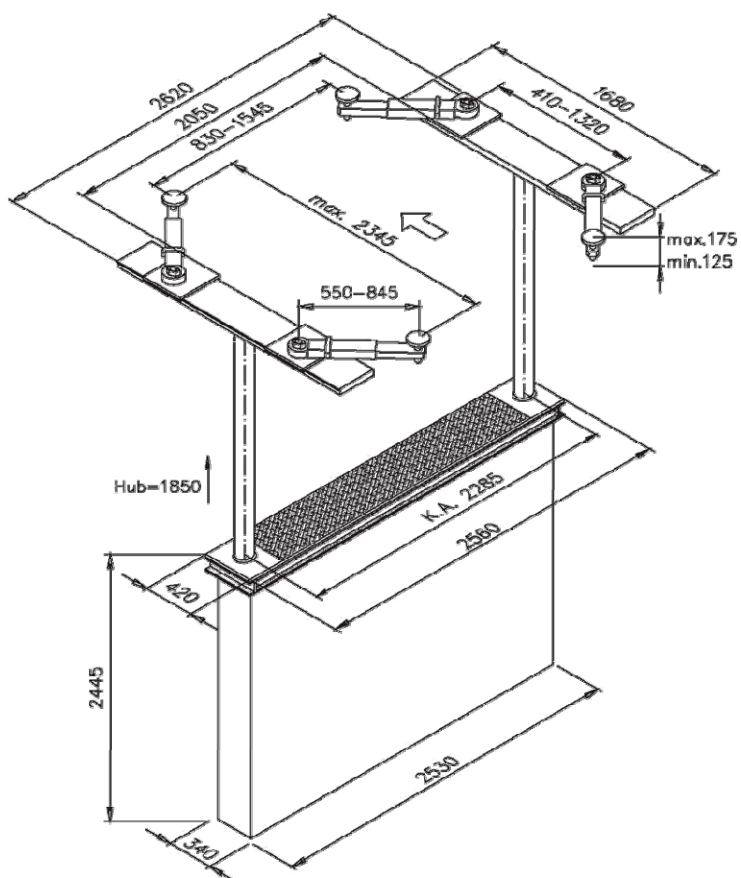

Master Body 2.30
Sav 230

With telescopic arms and a lifting capacity of 3 t. Wide distance between pistons (2285 mm).

STENHØJ
lifting the level

Stenhøj Master Body

Stenhøj Master Body 2.40 Saav 230

Twin-ram underground lifts

Top safety

- flexible traverse cross arm effective as synchronizing/safety device as well as torsional lock
- automatic arm locking system
- obstruction system
- system against hose fractures
- alarm signal when lowering the lift

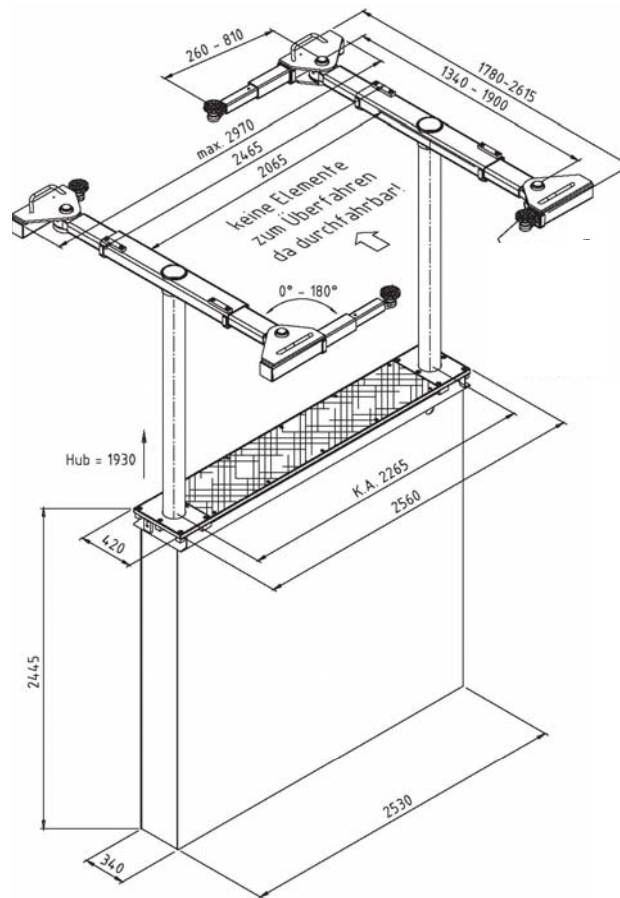

STENHØJ
lifting the level

Master Body 2.40 Saav 230

With double telescopic arms, movable superstructure, adjustable in length and a lifting capacity of 4 t. Wide distance between pistons (2265 mm)

Stenhøj Master Body

SURFACE TREATMENT

Corrosion inhibited steel cassette, which on request can be delivered as self-carrying and galvanized or plastic coated. Superstructure has been primed and then given two-component paint.

<u>Technical data</u>	2.30 Sav 230	2.40 Saav 230
Lifting capacity	3000 kg	4000 kg
Lifting/lowering time	30 sec.	30 sec.
Stroke length	1850 mm	1960 mm
Distance between pistons	2285 mm	2265 mm
Hydraulic pump	3 kW	3 kW

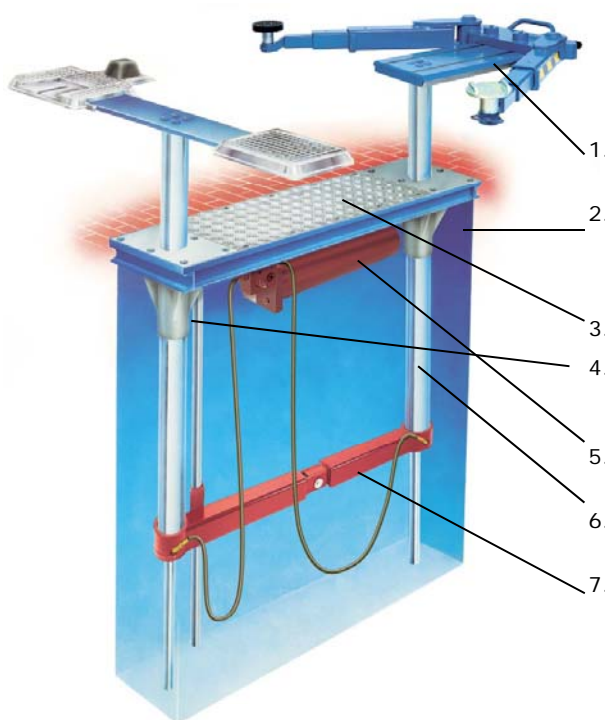

1. Superstructure and control unit with alarm signal.
2. Corrosion protected steel cassette. Also available as self-carrying, galvanized and plastic-coated cassette.
3. Aluminium/wooden cover.
4. Corrosion-free and stable guiding elements out of a special alloy.
5. Compact pump unit with oil submerged motor.
6. Hard-chrome plated cylinders with internal pistons.
7. Maintenance-free synchronization system.



STENHØJ
lifting the level

Stenhøj Autolift A/S
Denmark

Tel: +45 76 82 13 30
Fax: +45 76 82 13 31
Mail: autolift@stenhoj.dk
Web: www.stenhoj.dk

Standard colour

Red RAL 3013

No liability accepted for specifications, which are subject to alteration.