

ET66



➤ Dual display control panel



»» General Description

A compact, extremely precise display balancing machine for truck wheels, the ET 66, is fitted on wheels for improved handling and ease of transport, **is particularly suitable for external use**

on equipped vehicles. The ET66 has a dual display control panel which is designed to be user friendly. It is equipped with an integrated lift for raising wheels up to 150kg and is sup-

plied with a wide choice of balancing programs. Available in manual or motor-driven spin device versions, it also operates with a 12V battery.

	ET 66 M	ET 66 HS
Car wheel balancing speed	120 rpm	120 rpm
Truck wheel balancing speed	80 rpm	80 rpm
Maximum unbalance value calculated	1990 g	1999 g
Resolution (car/truck)	1 g / 10 g	1 g / 10 g
Average spin time for car wheels	8 s	-
Average spin time for truck wheels	18 s	-
Shaft diameter	46 mm	46 mm
Rim width setting range for car wheels	1,5" ÷ 16"	1,5" ÷ 16"
Rim width setting range for truck wheels	4" ÷ 20"	4" ÷ 20"
Rim diameter setting range for car wheels	8" ÷ 20"	8" ÷ 20"
Rim diameter setting range for truck wheels	12" ÷ 28"	12" ÷ 28"
Maximum wheel/machine distance	400 mm	400 mm
Maximum wheel diameter	1320 mm	1320 mm
Maximum wheel weight	150 kg	150 kg
Power supply	115/230 V 1ph	115/230 V 1ph
Total power absorption	160 W	10 W
Machine weight	146 kg	133 kg

Technical Data

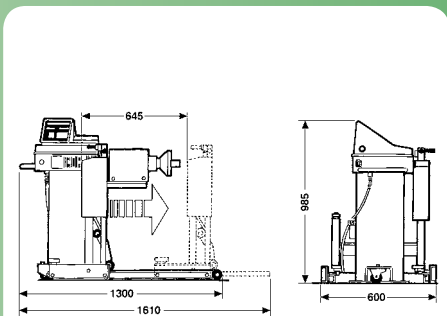

»» Principal characteristics

- ❑ Electronic balancing machine with microprocessor for off-vehicle wheels of trucks, buses and vans
- ❑ **Low balancing speed** (80 rpm for truck wheels and 120 rpm for car wheels) reduces wheel spin times, reduces the risks due to rotating parts and saves energy
- ❑ **Integrated pneumatic lift** for wheels weighing up to 150 kg
- ❑ Manual brake for locking the wheel shaft
- ❑ Cover with trays to take weights of all kinds and the most commonly used accessories
- ❑ Unbalance data acquisition at **variable speed**
- ❑ Motor-driven wheel spin (Motor version) or manual (Hand Spin version)
- ❑ Dual luminous digital display
- ❑ Simple, user-friendly keyboard for data input and program selection
- ❑ Processing unit with 16 bit microprocessor
- ❑ 1g (1/10oz) resolution in car function and 10g (0,5oz) in truck function
- ❑ Unbalance values displayed in grams or ounces
- ❑ Balancing modes available:
 - Standard dynamic on both sides of the rim
 - Alu for alloy rims
 - Static on one plane only
- ❑ Utility programs:
 - calibration
 - diagnostics
- ❑ Kit for external 12V battery power supply available on request (for Hand Spin version only)



➤ Manual wheel spin version (Hand Spin)



➤ Integrated pneumatic lift for wheels weighing up to 150 kg



This product has been certified by:

